



## DHZ 660

DHZ-660 is a professional oil-based haze machine. Using high-pressure atomization technology, no heating system, to produce haze without waiting for pre-heat up. Selected best quality component ensure the professional haze effect and durability. Updated nozzle provides better haze effect. Extremely low fluid consumption rate and long time continuous output, suit for all kinds of indoor and outdoor performances.

### Power supply system and output

Voltage	240V 50Hz	Tank Capacity	2.5 Ltr.
Power	500W	Fluid Consumption	25 hrs/Ltr
Heat-up time	0 min	Liquid type	Oil Base
Output	3,200 cu.ft/min.	DMX Personality	2 channel

### Appearance parameters

Structure	Steel case	Size	380 x 500 x 350mm
IP Rate	IP20	Net weight	35 Kg

Channel	DMX Value	Function
1	0 - 5	Off
	6 - 255	Haze output Low > High
2	0 - 5	Off
	6 - 255	Fan output Low > High

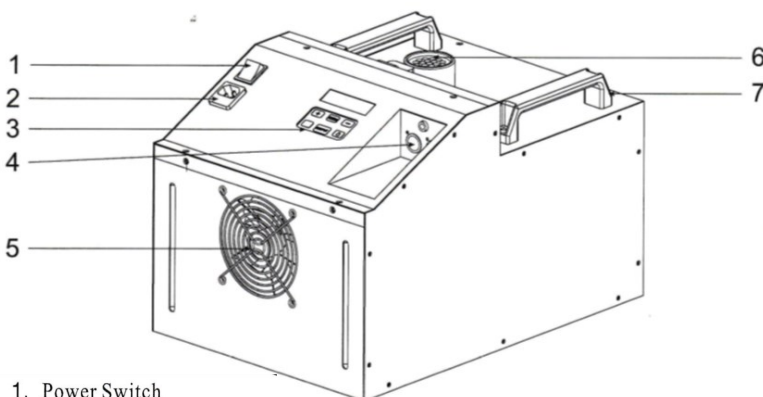

1. Power Switch
2. Power Socket
3. Control Panel
4. DMX Socket
5. Cooling Exhaust Fan
6. Smoke Nozzle
7. Handle
8. Adjust The Angle Of The Lid
9. Smoke Nozzle

