

# TOP TRUSS

## 400 Tri Truss

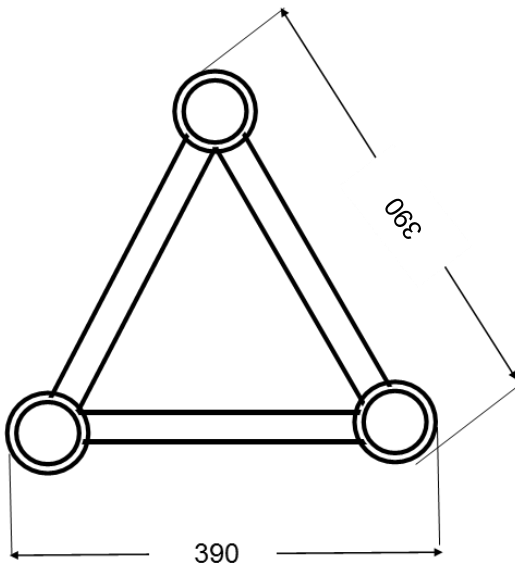

The C40 triangle truss is designed as a medium duty truss system. The system is connected via a special conical connector with excellent strength and stability, creating optimal traction convenient for assembly and collection. All the tubes and connectors welding through the mould of semi-automatic, the finished products are fixed in the standard mould welding can be guarantee the accuracy of truss in any conditions connect smoothly. This item is approved by TUV SUD certificate in Germany.

### Technical Specifications - C40 Series

- Section type                      Triangular Truss
- Material                              Alloy EN-AW 6082-T6
- Main tubes                          50 x 3mm tube
- Brace                                  20 x 2mm tube



C40 Tri truss - 290 x 290mm

Truss length (L)	5M	6M	7M	8M	9M	10M	11M	12M	13M	14M	15M	16M	17M	18M	19M	20M
Centre load Kg	796.2	585.1	497.2	429.5	377.1	335.5	300.6	270.4	245.2	222.4	202.5	185.5	168.5	155	142	130.4
Deviation in mm.	15	21	30	40	52	65	78	90	100	125	145	160	185	205	230	250
Evenly distributed load Kg	1170.5	989.5	824.1	712.5	625.2	555.2	495.5	447.2	405.2	366.5	335.2	305.5	280.5	258.5	232.5	210
Deviation in mm.	1	16	25	35	40	50	60	75	85	102	115	132	145	167	185	200

CODE	Length	Dimension	CBM	N.W.
D005C	0.5M	L55 x W41 x H34mm	0.08M sq.	4.90 Kg
D010C	1.0M	L105 x W41 x H34mm	0.16M sq.	8.10 Kg
D020C	2.0M	L205 x W41 x H34mm	0.31M sq.	12.80 Kg
D030C	3.0M	L305 x W41 x H34mm	0.46M sq.	17.90 Kg
V040C	4.0M	L405 x W41 x H34mm	0.62M sq.	21.20 Kg

# CERTIFICATE

ZERTIFIKAT • CERTIFICATE • CERTIFICADO • CERTIFICAT • СЕРТИФИКАТ



TUV  
SUD  
Industrie Service

## CERTIFICATE

Conformity of the Factory Production Control  
**0036-CPR-1090-1.00245.TUV SÜD.2015.001**

In compliance with Regulation 305/2011/EU of the European Parliament and of the Council of 9 March 2011 (The Construction Products Regulation or CPR), this certificate applies to the following construction product:

<b>Construction product</b>	<b>Structural components and kits for aluminum structures to EN1090-2</b>
<b>Intended use</b>	for load-bearing structures in all types of buildings
<b>CE - marking method</b>	ZA 3.2 and ZA 3.4 acc. to EN 1090-1:2009+A2:2011
<b>Range of production</b>	see reverse
<b>Manufacturer</b>	<b>Toptruss Performance Equipment Co., Ltd.</b> No. 9, Seven Road B Area 528226 Foshan City CHINA
<b>Manufacturing plant</b>	Toptruss Performance Equipment Co., Ltd. No. 9, Seven Road B Area 528226 Foshan City CHINA
<b>Confirmation</b>	This certificate attests that all provisions concerning the assessment and verification of constancy of performance described in Annex ZA of the harmonised standard <b>EN 1090-1:2009+A1:2011</b> under system 2+ are applied, and that the factory production control fulfils all the prescribed requirements stated therein.
<b>Start of validity</b>	20.01.2015
<b>Next surveillance audit</b>	20.01.2018
<b>Period of validity</b>	This certificate will remain valid as long as the test methods and/or the factory production control requirements included in the harmonised standard used to assess the performance of the declared characteristic do not change, and the product and the manufacturing conditions in the plant are not modified significantly.
<b>Remarks</b>	see reverse
<b>Place and date of issue</b>	Munich, 20.01.2015 Lu Senfeng



TUV SÜD Industrie Service GmbH • Alteisen-Werkhof • Schwanenstraße 19 • 8080 München • Germany





TOPTRUSS products successfully passed the Germany TÜV SÜD certification through the first-class technology, high-quality staff, excellent quality and safety.

TÜV SÜD group is one of the largest technical detection, inspect and quality certification body, as Europe and the world's most authoritative certification, always is famous for its rigorous quality testing certification service. With the most advanced technology, the most stringent testing and certification standards to conduct a comprehensive inspection of product quality and provide various professional evaluation.

Germany TÜV SÜD certificate is one of Chinese products into European and American market, through this certification mean that the products comply with European and American countries technical standards.

ZERTIFIKAT • CERTIFICATE • CERTIFICADO • CERTIFICAT • СЕРТИФИКАТ



TUV  
SUD  
Industrie Service

## Welding Certificate

**TUV SÜD-00245.2015.001**

In accordance with EN 1090-2, table B 1, it is hereby declared: The manufacturer has produced evidence that he fulfils the requirements of the European standard EN 1090-2 for evaluation of structural aluminium components

<b>Manufacturer</b>	<b>Toptruss Performance Equipment Co., Ltd.</b> No. 9, Seven Road B Area CN 528226 Foshan City
<b>Technical specification</b>	<b>EN 1090-2:2008</b>
<b>Execution class(es)</b>	<b>EXC3 according to EN 1090-2</b>
<b>Welding Process(es)</b>	141 - TIG gas tungsten arc welding
<b>Material Group</b>	23 according to EN 50878 13008 and EN 1090-2, table 1 and 2
<b>Responsible Welding Coordinator</b>	Zhang Jing, IWS <span style="float: right;">born on: 21.01.1985</span>
<b>Substitute</b>	Su Shuai, engineer <span style="float: right;">born on: 27.11.1991</span>
<b>Confirmation</b>	All provisions concerning welding as described in the above mentioned technical specification(s) were applied.
<b>Validity start</b>	20.01.2015
<b>Period of validity</b>	20.01.2018
<b>Remarks</b>	see reverse
<b>Place and date of issue</b>	Munich, 20.01.2015 Lu Senfeng



TUV SÜD Industrie Service GmbH • Alteisen-Werkhof • Schwanenstraße 19 • 8080 München • Germany







TUV  
SUD  
Industrie Service

## CERTIFICATE

The company

**Toptruss Performance Equipment Co., Ltd.**  
No. 9, Seven Road B Area  
CHN - 528226 Foshan City  
P.R. China

fulfils the  
**Comprehensive Quality Requirements** according to  
**EN ISO 3834-2**

for the range mentioned in the enclosure to this certificate.

The certificate expires in January 2018.

Report No. 221699  
Munich, January 20<sup>th</sup>, 2015

TUV SÜD Industrie Service GmbH  
Westendstrasse 199, D-80698 München

Department  
Material and Welding Technology

  
 Dipl.-Ing. (FH) Tobias Strödel



TUV SÜD Industrie Service GmbH • Alteisen-Werkhof • Schwanenstraße 19 • 8080 München • Germany





ZERTIFIKAT • CERTIFICATE • CERTIFICADO • CERTIFICAT • СЕРТИФИКАТ

# CERTIFICATE

**Benannte Stelle nach Druckgeräterichtlinie (97/23/EG)**  
**der TÜV SÜD Industrie Service GmbH**

**ZERTIFIKAT - QUALIFIZIERUNG VON SCHWEISSVERFAHREN (WPQR)**  
WELDING PROCEDURE QUALIFICATION RECORD - CERTIFICAT DE QUALIFICATION EN WELDING OPERATIONS DE SOUDAGE

**Zusammenfassung**  
Certification No.: 0336 / SHA / 148210819-08  
Date of approval: 2015-01-10  
Page: 1 of 2

**Hersteller / Applicant**  
Tiptop Performance Equipment Co., Ltd / 天拓工业设备有限公司  
Seven Road, 8 Area, Jiaolan Qiang Industrial District, Nanhai, Foshan City, Guangdong Province, 528226, P.R. China

**Verfahrensnummer**  
EN ISO 15614-2

**Technische Details**  
Welding: 14 (Manual)  
Material: 890 in Pipe  
Welding Position: 1G to 2G  
Welding Process: 141  
Welding Procedure: 2  
Welding Parameter: 1.5 to 6 (2)  
Welding Temperature: 423 (20)  
Welding Temperature Range: 400-450 (20)  
Welding Temperature Range: 400-450 (20)  
Welding Temperature Range: 400-450 (20)  
Welding Temperature Range: 400-450 (20)

**Welding Details**  
Welding Position: 1G to 2G  
Welding Process: 141  
Welding Procedure: 2  
Welding Parameter: 1.5 to 6 (2)

**Other Information**  
1. More photos see annex 1.

**Benannte Stelle nach Druckgeräterichtlinie (97/23/EG)**  
**der TÜV SÜD Industrie Service GmbH**

**EINZELHEITEN ZUR PRÜFSTÜCKSCHWEISSUNG (1)**  
DETAILS OF WELD TEST (1) - DÉTAILS DU TROUVEAU Soudage (1)

**Zusammenfassung**  
Certification No.: 0336 / SHA / 148210819-08  
Date of approval: 2015-01-10  
Page: 2 of 2

**Hersteller / Applicant**  
Tiptop Performance Equipment Co., Ltd  
Seven Road, 8 Area, Jiaolan Qiang Industrial District, Nanhai, Foshan City, Guangdong Province, 528226, P.R. China

**Verfahrensnummer**  
EN ISO 15614-2

**Technische Details**  
Welding: 14 (Manual)  
Material: 890 in Pipe  
Welding Position: 1G to 2G  
Welding Process: 141  
Welding Procedure: 2  
Welding Parameter: 1.5 to 6 (2)

**Welding Details**  
Welding Position: 1G to 2G  
Welding Process: 141  
Welding Procedure: 2  
Welding Parameter: 1.5 to 6 (2)

**Other Information**  
1. More photos see annex 1.

**Benannte Stelle nach Druckgeräterichtlinie (97/23/EG)**  
**der TÜV SÜD Industrie Service GmbH**

**ZERTIFIKAT - QUALIFIZIERUNG VON SCHWEISSVERFAHREN (WPQR)**  
WELDING PROCEDURE QUALIFICATION RECORD - CERTIFICAT DE QUALIFICATION EN WELDING OPERATIONS DE SOUDAGE

**Zusammenfassung**  
Certification No.: 0336 / SHA / 148210819-08  
Date of approval: 2015-01-10  
Page: 1 of 2

**Hersteller / Applicant**  
Tiptop Performance Equipment Co., Ltd / 天拓工业设备有限公司  
Seven Road, 8 Area, Jiaolan Qiang Industrial District, Nanhai, Foshan City, Guangdong Province, 528226, P.R. China

**Verfahrensnummer**  
EN ISO 15614-2

**Technische Details**  
Welding: 14 (Manual)  
Material: 890 in Pipe  
Welding Position: 1G to 2G  
Welding Process: 141  
Welding Procedure: 2  
Welding Parameter: 1.5 to 6 (2)

**Welding Details**  
Welding Position: 1G to 2G  
Welding Process: 141  
Welding Procedure: 2  
Welding Parameter: 1.5 to 6 (2)

**Other Information**  
1. More photos see annex 1.

**Benannte Stelle nach Druckgeräterichtlinie (97/23/EG)**  
**der TÜV SÜD Industrie Service GmbH**

**EINZELHEITEN ZUR PRÜFSTÜCKSCHWEISSUNG (1)**  
DETAILS OF WELD TEST (1) - DÉTAILS DU TROUVEAU Soudage (1)

**Zusammenfassung**  
Certification No.: 0336 / SHA / 148210819-08  
Date of approval: 2015-01-10  
Page: 2 of 2

**Hersteller / Applicant**  
Tiptop Performance Equipment Co., Ltd  
Seven Road, 8 Area, Jiaolan Qiang Industrial District, Nanhai, Foshan City, Guangdong Province, 528226, P.R. China

**Verfahrensnummer**  
EN ISO 15614-2

**Technische Details**  
Welding: 14 (Manual)  
Material: 890 in Pipe  
Welding Position: 1G to 2G  
Welding Process: 141  
Welding Procedure: 2  
Welding Parameter: 1.5 to 6 (2)

**Welding Details**  
Welding Position: 1G to 2G  
Welding Process: 141  
Welding Procedure: 2  
Welding Parameter: 1.5 to 6 (2)

**Other Information**  
1. More photos see annex 1.